

INTERNATIONAL WOOD TRADE

WOOD GLAZED OR OPAQUE SINGLE DOOR

INSWING/OUTSWING "NON-IMPACT"

GENERAL NOTES

1. This product has been evaluated and is in compliance with the 5th Edition (2014) Florida Building Code (FBC) structural requirements excluding the "High Velocity Hurricane Zone" (HVHZ).
2. Product anchors shall be as listed and spaced as shown on details. Anchor embedment to base material shall be beyond wall dressing or stucco.
3. When used in areas requiring wind borne debris protection, this product is required to be protected with an impact resistant covering that complies with Section 1609.1.2 of the FBC.
4. For 2x stud framing construction, anchoring of these units shall be the same as that shown for 2x buck masonry construction.
5. Site conditions that deviate from the details of this drawing require further engineering analysis by a licensed engineer or registered architect.

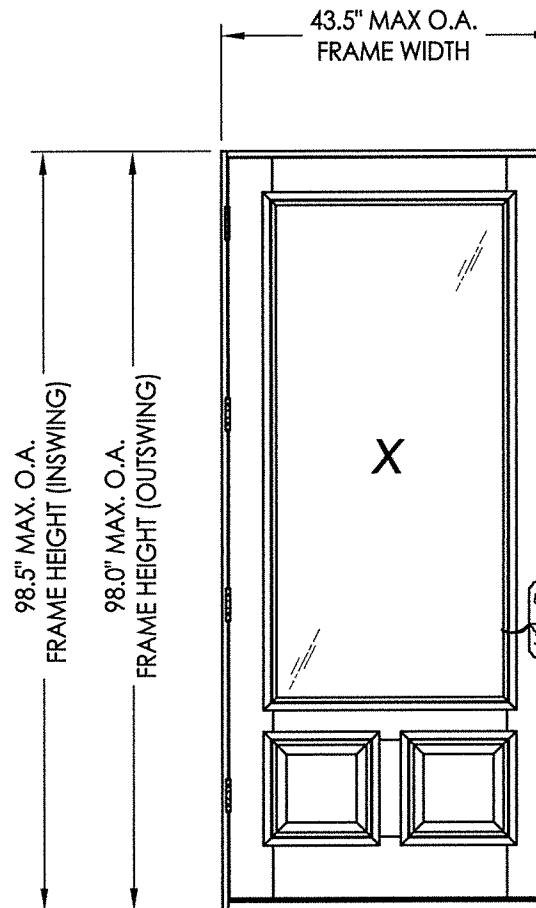
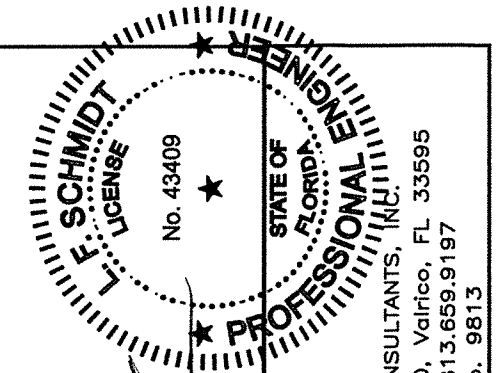

TABLE OF CONTENTS	
SHEET#	DESCRIPTION
1	Typical Elevations, Design Pressures & General Notes
2	Door Panel Details
3	Elevations
4	Horizontal & Vertical Cross Sections (2X Buck)
5	Horizontal & Vertical Cross Sections (1X Buck)
6	Horizontal & Vertical Cross Sections (Direct to Masonry)
7	Vertical Cross Sections (Thresholds)
8	Buck & Frame Anchoring
9	Hardware Details
10	Bill of Materials & Components

CONFIGURATION	LOCK HARDWARE	DESIGN PRESSURE (PSF) INSWING		DESIGN PRESSURE (PSF) OUTSWING	
		POSITIVE	NEGATIVE	POSITIVE	NEGATIVE
X	Multipoint*	+75.0	-80.0	+75.0	-75.0

*See Sheet 3 for Hardware Specifications



LFS
8-24-16

Documents Prepared By:
Lyndon F. Schmidt
P.E. No. 43409

RW BUILDING CONSULTANTS, INC.
P.O. Box 230, Valrico, FL 33595
Phone No.: 813.659.9197
FBPE C.A. No. 9813

PRODUCT:
INTERNATIONAL WOOD TRADE
WOOD DOOR

PART OR ASSEMBLY:
TYPICAL ELEVATION, DESIGN
PRESSURES & GENERAL NOTES

NO.	DATE	BY	REVISIONS

DATE: 8/17/16
SCALE: N.T.S.
DWG. BY: JK
CHK. BY: LFS
DRAWING NO.: FL-20800.4
SHEET 1 OF 10

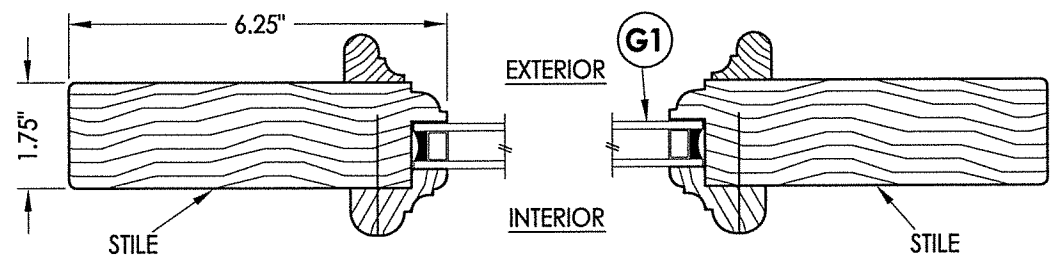

1 HORIZONTAL CROSS SECTION

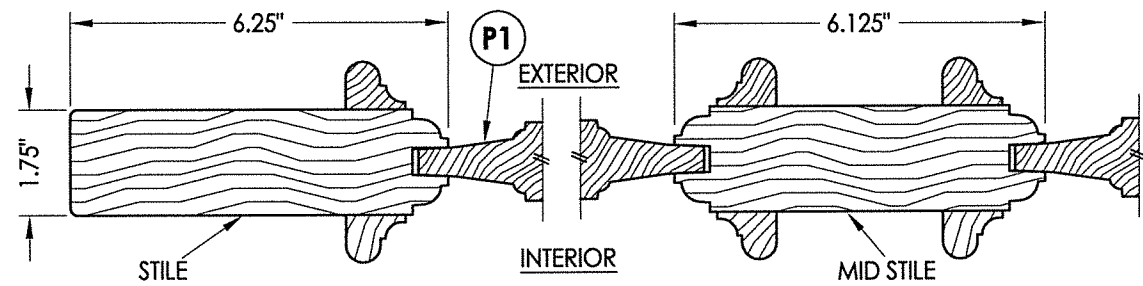

2 HORIZONTAL CROSS SECTION

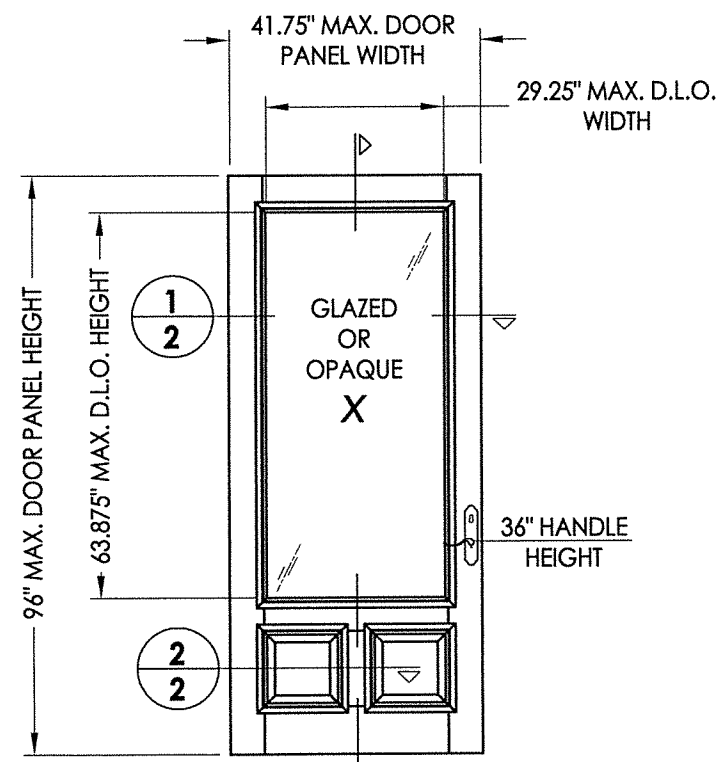

40 WOOD DOOR PANEL
Glazed or Opaque

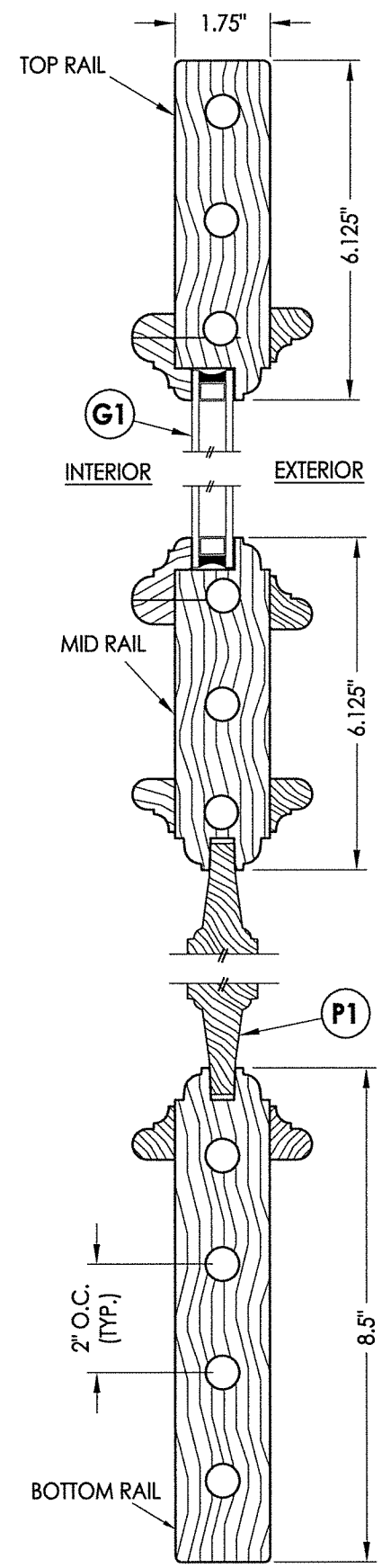
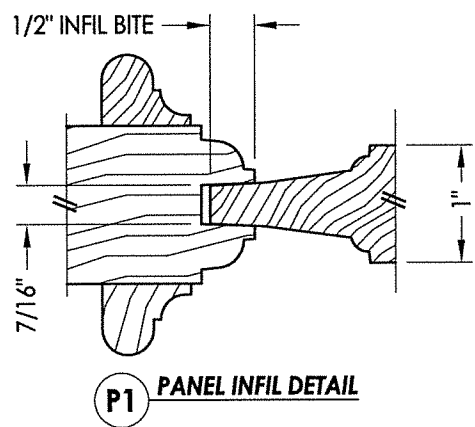
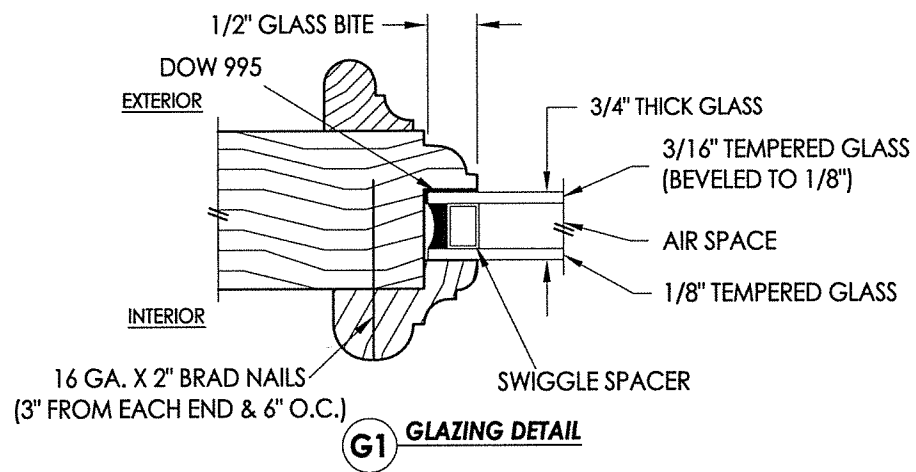

3 VERTICAL CROSS SECTION

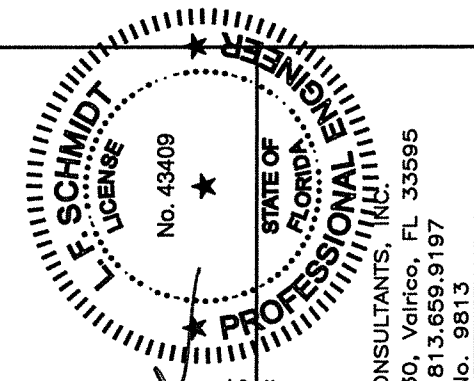

Documents Prepared By:
Lyndon F. Schmidt
P.E. No. 43409
8.24.16
R.W. BUILDING CONSULTANTS, INC.
P.O. Box 230, Vairico, FL 33595
Phone No.: 813.659.9197
FBPE C.A. No. 9813

PRODUCT:	INTERNATIONAL WOOD TRADE WOOD DOOR
PART OR ASSEMBLY:	DOOR PANEL DETAILS

NO.	DATE	BY	REVISIONS

DATE:	8/10/16
SCALE:	N.T.S.
DWG. BY:	JK
CHK. BY:	LFS
DRAWING NO.:	FL-20800.4
SHEET	2 OF 10

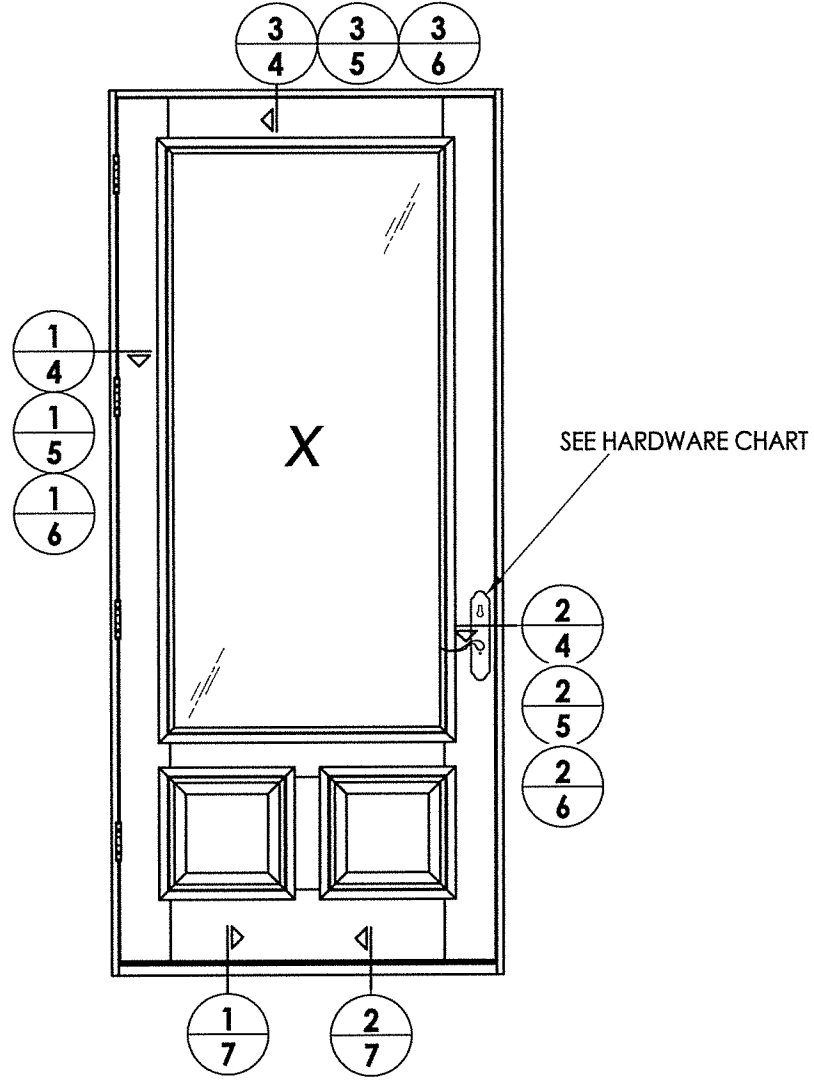

HARDWARE TABLE	
MANUFACTURER	MODEL
G-U	MULTIPOINT LOCK (3-pt Tongue): SECURY AUTOMATIC DOOR LOCK FOR LEVER HANDLE (6-35856-01-R-8B) MORTISE LOCK TRIM: EMTEK

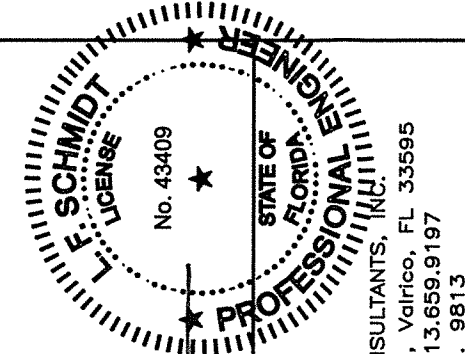

LFR
8.24.16

Documents Prepared By:
Lyndon F. Schmidt
P.E. No. 43409

RW BUILDING CONSULTANTS, INC.
P.O. Box 230, Vairico, FL 33595
Phone No.: 813.659.9197
FBPE C.A. No. 9813

PRODUCT:
INTERNATIONAL WOOD TRADE
WOOD DOOR

PART OR ASSEMBLY:
ELEVATIONS

NO.	DATE	BY	REVISIONS

DATE: 8/10/16
SCALE: N.T.S.
DWG. BY: JK
CHK. BY: LFS
DRAWING NO.: FL-20800.4
SHEET 3 of 10

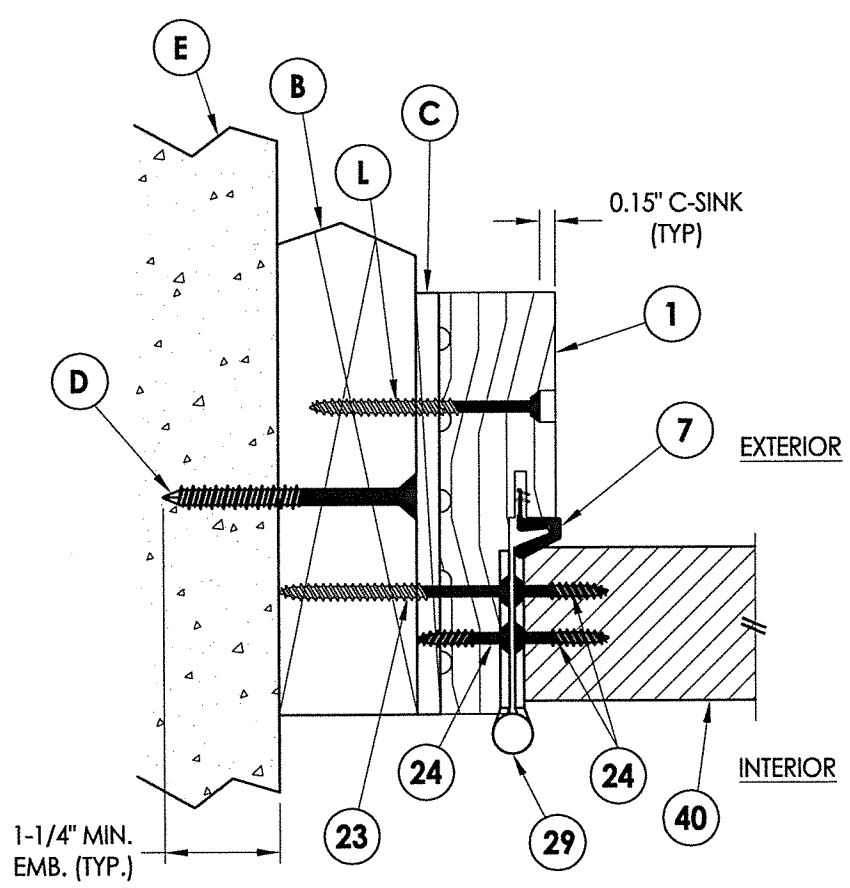

1 HORIZONTAL CROSS SECTION
 4 Shown w/ 2X Buck
 Inswing shown (Outswing similar)

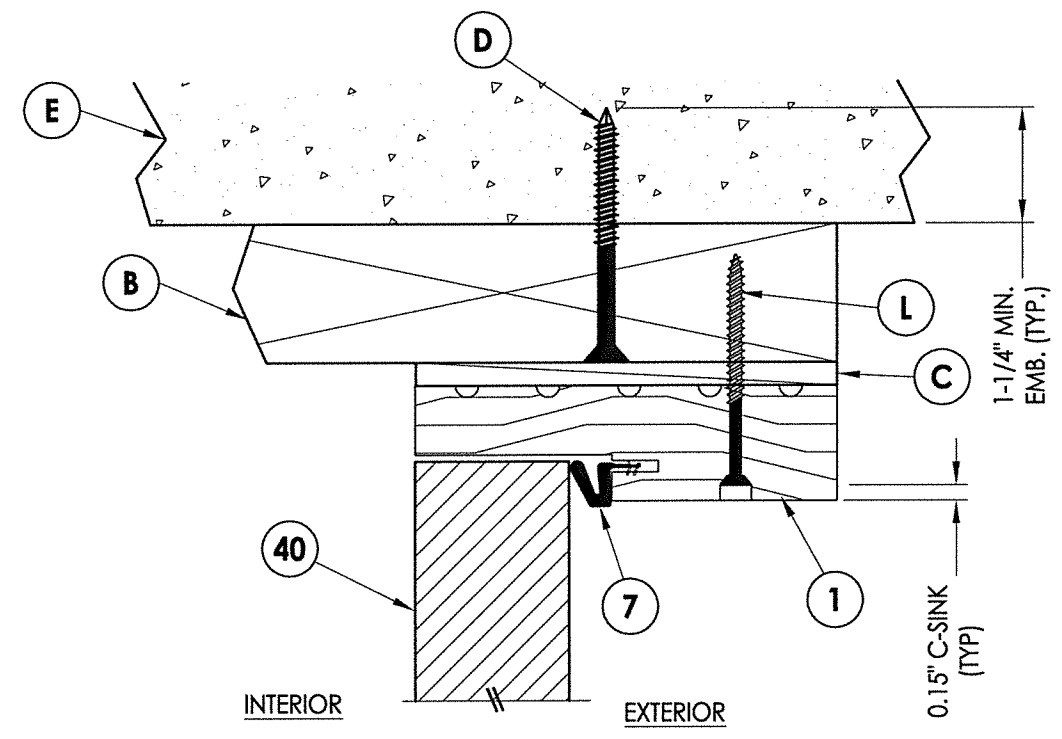

3 VERTICAL CROSS SECTION
 4 Shown w/ 2X Buck
 Inswing shown (Outswing similar)

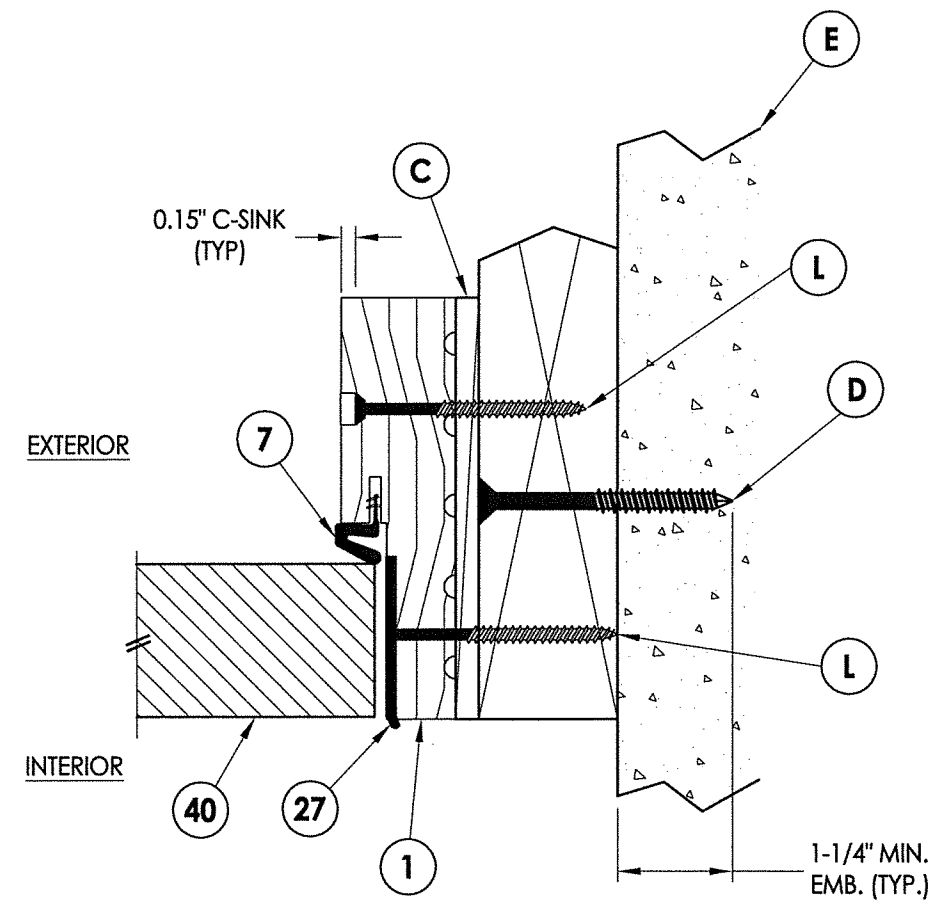

2 HORIZONTAL CROSS SECTION
 4 Shown w/ 2X Buck
 Inswing shown (Outswing similar)

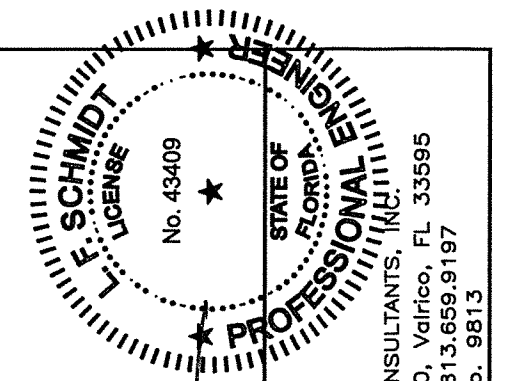

Documents Prepared By:
 Lyndon F. Schmidt
 P.E. No. 43409
 R.W. BUILDING CONSULTANTS, INC.
 P.O. Box 230, Valrico, FL 33595
 Phone No.: 813.659.9197
 FBPE C.A. No. 9813

PRODUCT:
 INTERNATIONAL WOOD TRADE
 WOOD DOOR
 PART OR ASSEMBLY:
 HORIZONTAL & VERTICAL
 CROSS SECTIONS (2X BUCK)

NO.	DATE	BY	REVISIONS

DATE: 8/17/16
 SCALE: N.T.S.
 DWG. BY: JK
 CHK. BY: LFS
 DRAWING NO.: FL-20800.4
 SHEET 4 OF 10

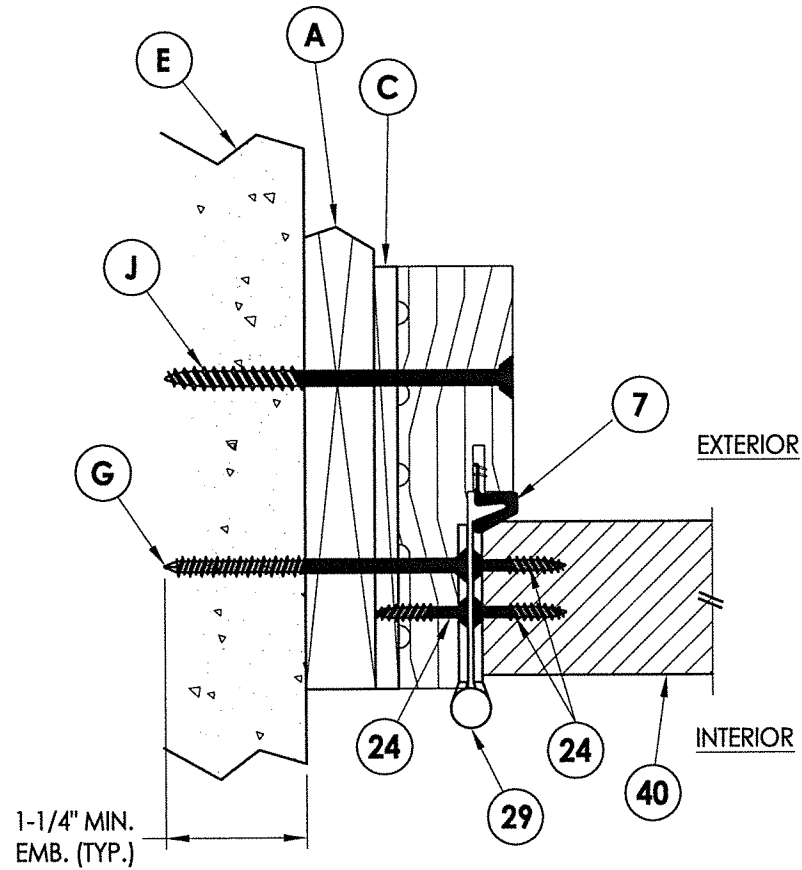

1 HORIZONTAL CROSS SECTION
 5 Shown w/ 1X sub-buck
 Inswing shown (Outswing similar)

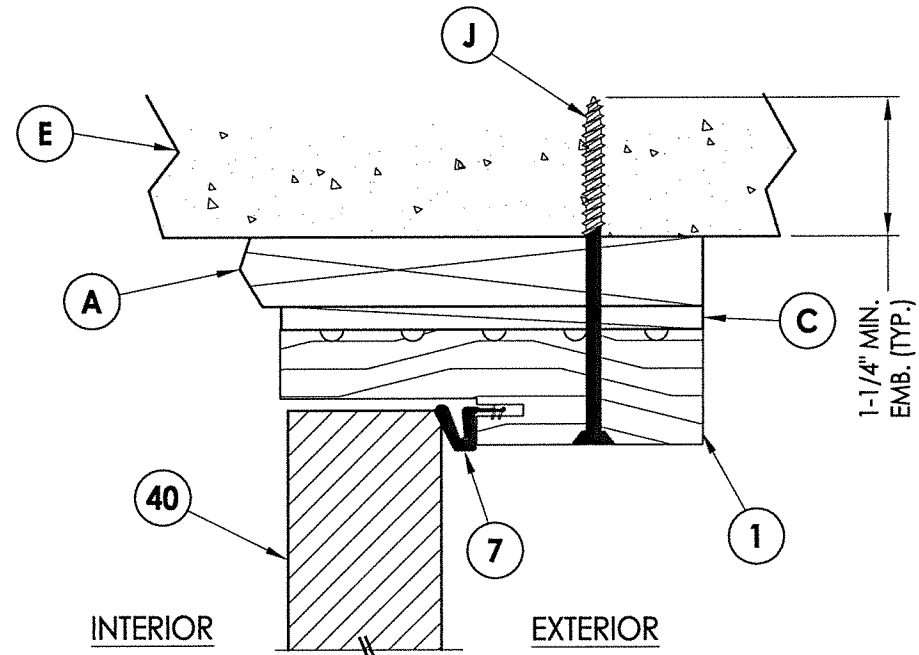

3 VERTICAL CROSS SECTION
 5 Shown w/ 1X sub-buck
 Inswing shown (Outswing similar)

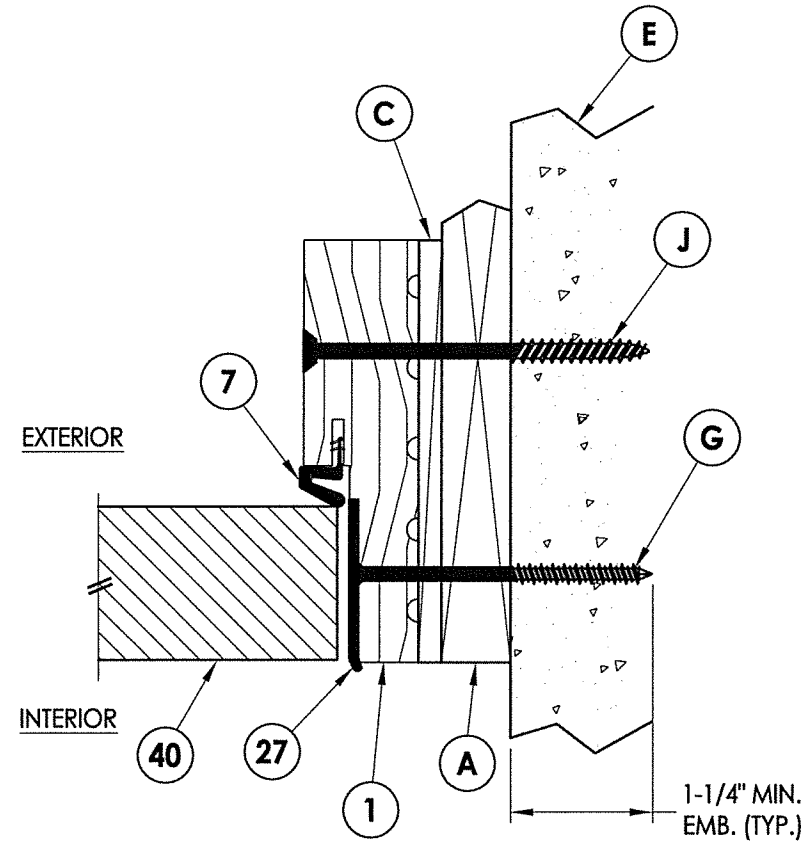

2 HORIZONTAL CROSS SECTION
 5 Shown w/ 1X sub-buck
 Inswing shown (Outswing similar)

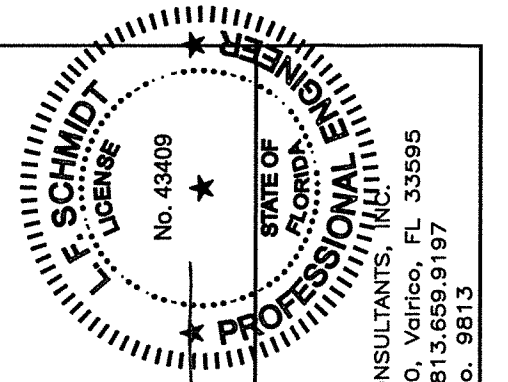

Documents Prepared By:
 Lyndon F. Schmidt
 P.E. No. 43409
 RW BUILDING CONSULTANTS, INC.
 P.O. Box 230, Vairico, FL 33595
 Phone No.: 813.659.9197
 FBPE C.A. No. 9813

PRODUCT:
 INTERNATIONAL WOOD TRADE
 WOOD DOOR
 PART OR ASSEMBLY:
 HORIZONTAL & VERTICAL
 CROSS SECTIONS (1X BUCK)

NO.	DATE	BY	REVISIONS

DATE: 8/17/16
 SCALE: N.T.S.
 DWG. BY: JK
 CHK. BY: LFS
 DRAWING NO.: FL-20800.4
 SHEET 5 OF 10

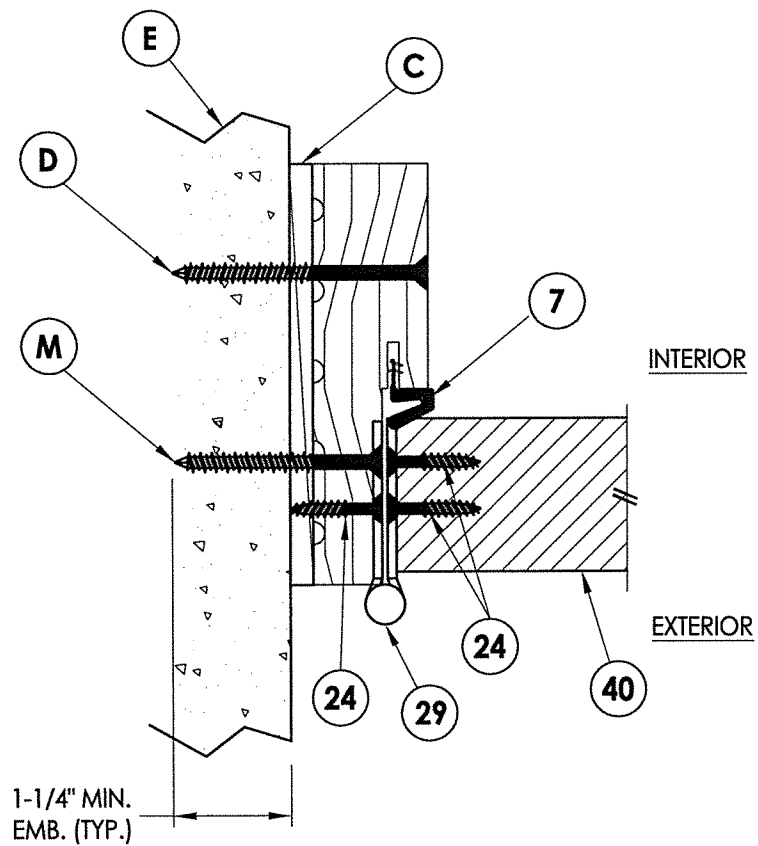

1 HORIZONTAL CROSS SECTION
6 Shown Direct to Masonry
 Outswing only

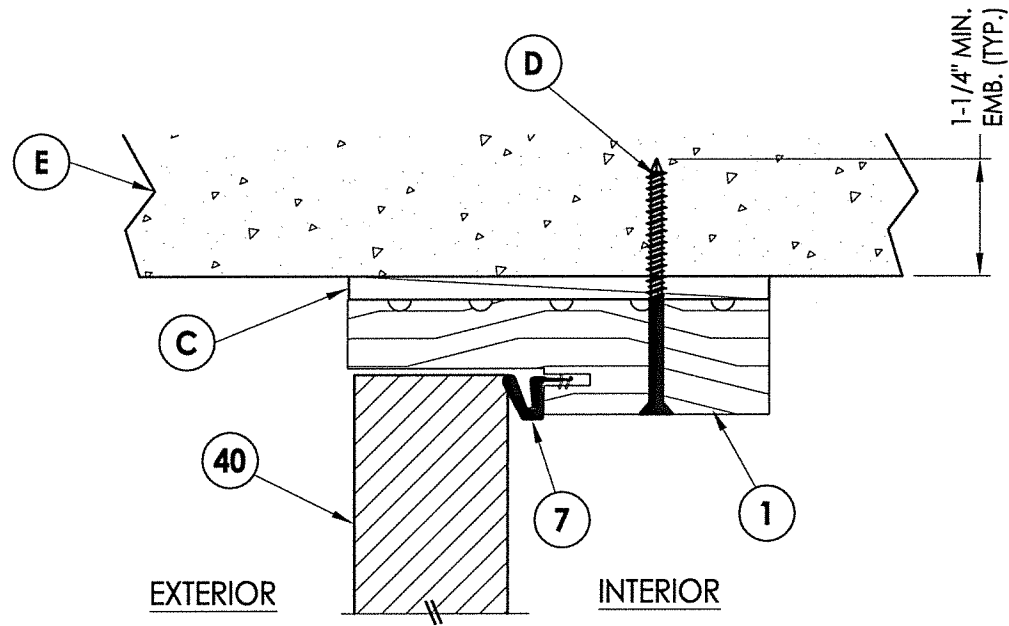

3 VERTICAL CROSS SECTION
6 Shown Direct to Masonry
 Outswing only

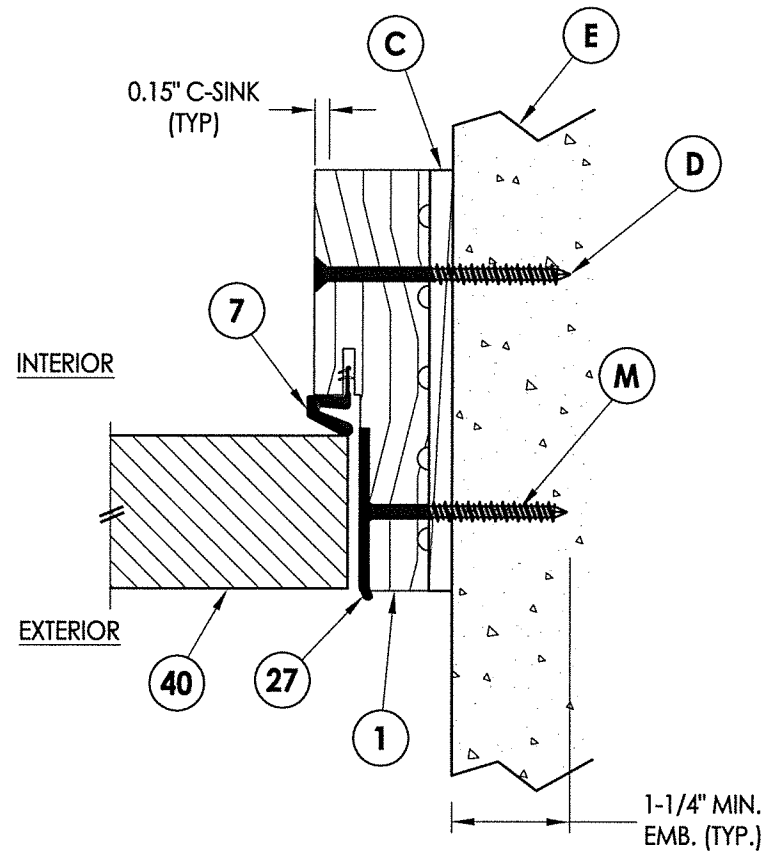

2 HORIZONTAL CROSS SECTION
6 Shown Direct to Masonry
 Outswing only

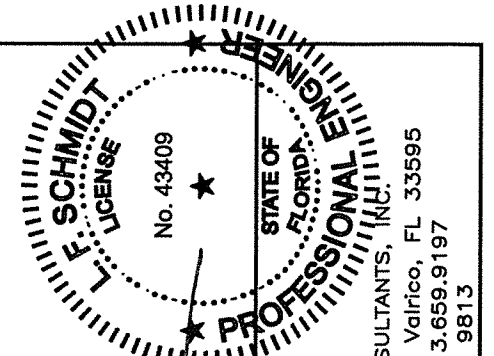

LFS
 8-29-16

Documents Prepared By:
 Lyndon F. Schmidt
 P.E. No. 43409

RW

BUILDING CONSULTANTS, INC.
 P.O. Box 230, Valrico, FL 33595
 Phone No.: 813.659.9197
 FBPE C.A. No. 9813

PRODUCT:
 INTERNATIONAL WOOD TRADE
 WOOD DOOR

PART OR ASSEMBLY:
 HORIZONTAL & VERTICAL CROSS
 SECTIONS (DIRECT TO MASONRY)

NO.	DATE	BY	REVISIONS

DATE: 8/17/16
 SCALE: N.T.S.
 DWG. BY: JK
 CHK. BY: LFS
 DRAWING NO.:
 FL-20800.4
 SHEET 6 OF 10

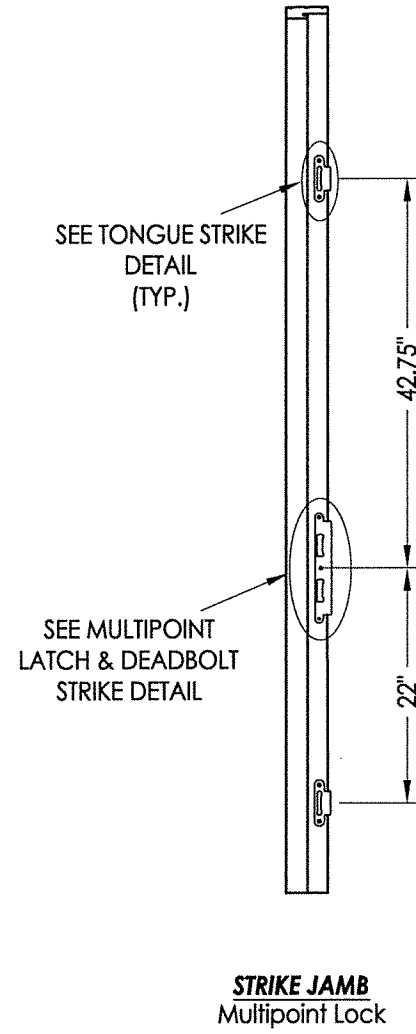
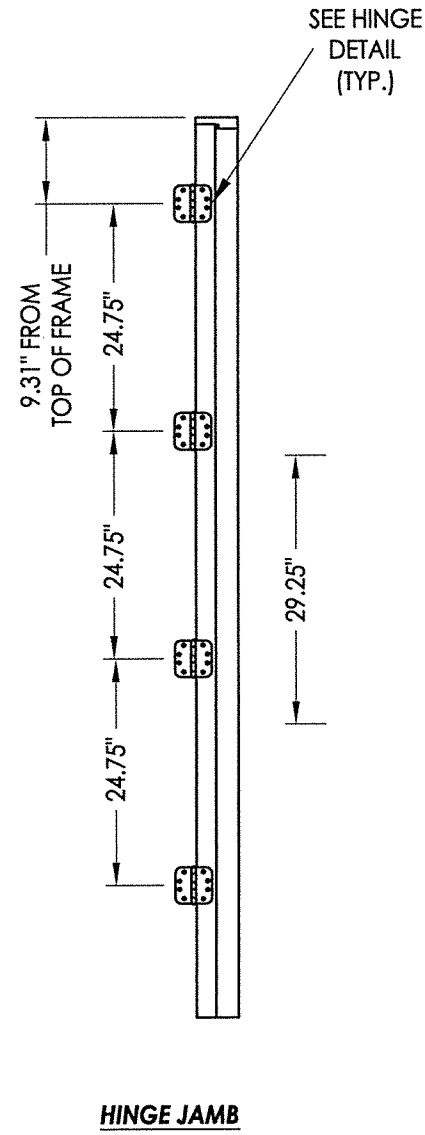
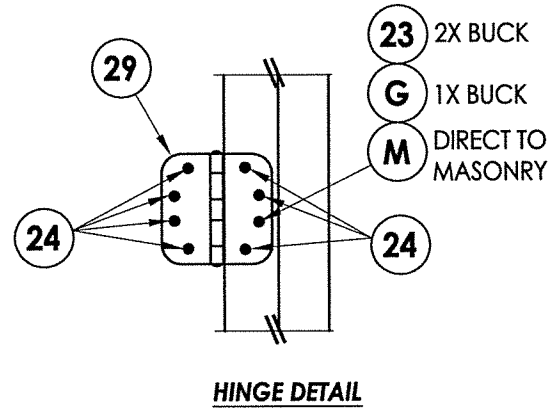

MULTIPOINT LOCK HARDWARE DETAILS

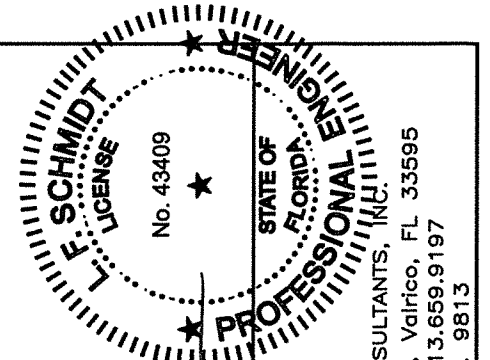
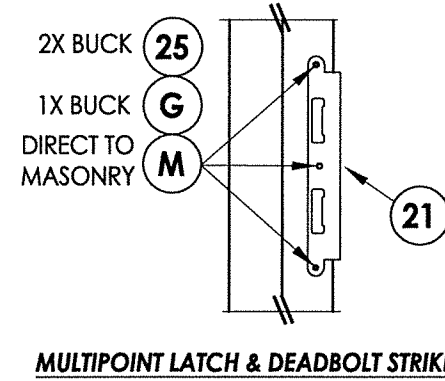
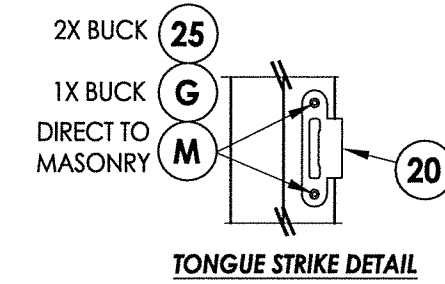

LFS
P-24.6

Documents Prepared By:
Lyndon F. Schmidt
P.E. No. 43409

R.W. BUILDING CONSULTANTS, INC.
P.O. Box 230, Valrico, FL 33595
Phone No.: 813.659.9197
FBPE C.A. No. 9813

PRODUCT: INTERNATIONAL WOOD TRADE WOOD DOOR

PART OR ASSEMBLY: HARDWARE DETAILS

NO.	DATE	BY	REVISIONS

DATE: 8/17/16

SCALE: N.T.S.

DWG. BY: JK

CHK. BY: LFS

DRAWING NO.: FL-20800.4

SHEET 9 OF 10

R:\Clients\International Wood Trade\A - Florida Product Approvals\FL-20800 Swinging Exterior Door Assemblies\C - Drawings\FL-20800 (2014)\FL-20800.4-6.dwg, 10.1

BILL OF MATERIALS

ITEM #	DESCRIPTION	MATERIAL
A	1X BUCK (SG >= 0.42)	WOOD
B	2X BUCK (SG >= 0.42)	WOOD
C	1/4" MAX. SHIM SPACE	-
D	1/4" X 2-3/4" PFH ELCO OR ITW CONCRETE SCREW	STEEL
E	MASONRY - 3,000 PSI MIN. CONCRETE CONFORMING TO ACI 301 OR HOLLOW BLOCK CONFORMING TO ASTM C90	CONCRETE
G	3/16" X 3-1/4" PFH ITW CONCRETE SCREW	STEEL
J	1/4" X 3-3/4" PFH ELCO OR ITW CONCRETE SCREW	STEEL
L	#10 X 2-1/2" PFH WOOD SCREW (1.15" MIN. EMBEDMENT)	STEEL
M	3/16" X 2-1/4" PFH ITW CONCRETE SCREW	STEEL
1	WOOD JAMB (SAPELE, G >= 0.55)	WOOD
7	WEATHERSTRIP	FOAM
8	SWEEP	VINYL
20	MULTIPOINT TONGUE STRIKE PLATE	STEEL
21	MULTIPOINT LATCH & DEADBOLT STRIKE PLATE	STEEL
23	#12 X 2-1/2" PFH WOOD SCREW	STEEL
24	#12 x 1-1/4" PFH WOOD SCREW	STEEL
25	#8 X 2-1/2" PFH WOOD SCREW	STEEL
27	LATCH STRIKE PLATE	STEEL
28	DEADBOLT STRIKE PLATE	STEEL
29	4" X 4" HINGE	STEEL
30	INSWING ADJUSTABLE THRESHOLD	ALUM/WOOD
35	OUTSWING BUMP THRESHOLD	ALUM/WOOD
40	DOOR PANEL	WOOD

CONCRETE ANCHOR NOTES:

- Concrete anchor locations at the corners may be adjusted to maintain the min. edge distance to mortar joints.
- Concrete anchor locations noted as "MAX. ON CENTER" must be adjusted to maintain the min. edge distance to mortar joints, additional concrete anchors may be required to ensure the "MAX. ON CENTER" dimension are not exceeded.
- Concrete anchor table:

ANCHOR TYPE	ANCHOR SIZE	MIN. EMBEDMENT	MIN. CLEARANCE TO MASONRY EDGE	MIN. CLEARANCE TO ADJACENT ANCHOR
ITW TAPCON®	1/4"	1-1/4"	2"	4"
ELCO ULTRACON®	1/4"	1-1/4"	1"	4"
ITW TAPCON®	3/16"	1-1/4"	3"	1-1/2"

WOOD SCREW INSTALLATION NOTES:

- Maintain a minimum 5/8" edge distance, 1" end distance, & 1" o.c. spacing of wood screws to prevent the splitting of wood.

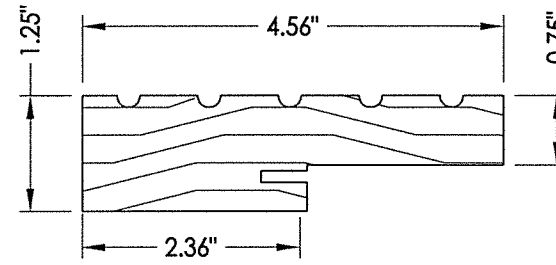

1 WOOD JAMB

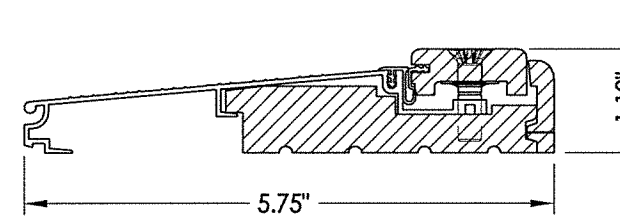

30 INSWING ADJUSTABLE THRESHOLD
Imperial 5Y

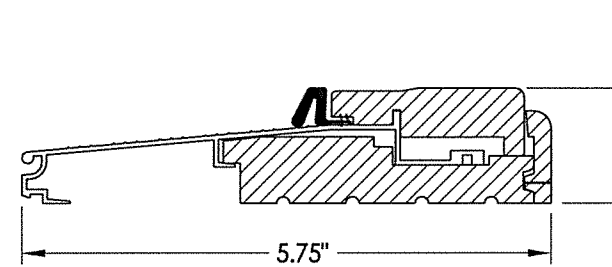

35 OUTSWING BUMB THRESHOLD
Imperial

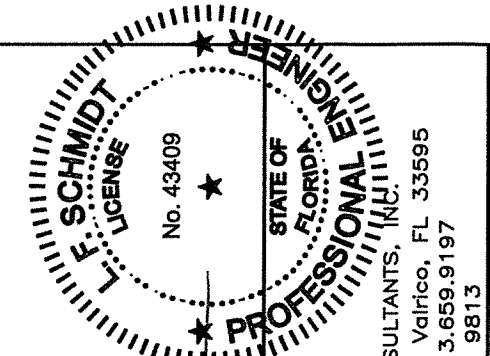

Lyndon F. Schmidt
P.E. No. 43409
R.W. BUILDING CONSULTANTS, INC.
P.O. Box 230, Vairico, FL 33595
Phone No.: 813.659.9197
FBPE C.A. No. 9813

PRODUCT:
INTERNATIONAL WOOD TRADE
WOOD DOOR
PART OR ASSEMBLY:
BILL OF MATERIALS
& COMPONENTS

NO.	DATE	BY

DATE: 8/17/16
SCALE: N.T.S.
DWG. BY: JK
CHK. BY: LFS
DRAWING NO.: FL-20800.4
SHEET 10 OF 10